

SOLAR THERMAL PLANTS – POWER AND PROCESS HEAT

Klaus-Jürgen Riffelmann, D. Krüger, R. Pitz-Paal
Deutsches Zentrum für Luft- und Raumfahrt e. V., D-51170 Köln

1 Introduction

The present paper consists of two parts: the first part gives an overview about the present state of solar thermal power plants. All technologies proven at least in field tests – Central Receiver Systems (CRS), Distributed Collector Systems (DCS) and Dish/Stirling Systems – are presented. The development of the solar key components and different plant concepts as well as actual research projects are described. Finally the levelized electricity costs are discussed. In the second part the DCS are regarded as technology for solar process heat generation. Some applications are described. In 1999 such a trough collector was erected and tested at the German Aerospace Center (DLR) in Cologne. The performance of the system was simulated for a location in a central European climate.

2 Solar Thermal Power Plants

2.1 Principles

In simple words a solar thermal power plant works like a conventional thermal power plant, but it uses solar energy instead of a fossil fuel as heat source. Solar Energy in general has two disadvantages: low energy density (about 1 kW/m²) and availability (day-night cycle, clouds). The second disadvantage can be faced by thermal storage systems, which shall not be treated in this paper. For further information concerning this issue refer to [1,2,3].

The first disadvantage would lead to low efficiency in the thermodynamic cycle of the power block. To face this the energy density of the solar radiation has to be increased by optical concentration.

Three different optical devices are currently used for concentration, they are described in this chapter.

2.2 The DCS-System

The Distributed Collector System - also called Trough System - is the only solar thermal technology in the world commercially used for electricity production. In the Californian Mojave Desert nine solar electricity generating systems (SEGS I – IX) were built between 1984 and 1991 with a total peak power of 354 MW_e supplied to the grid.

Figure 1 shows a scheme of the plant. Synthetic oil, used as heat transfer fluid, is heated up from 290 °C to 391 °C in the collectors. Superheated steam of 100 bar, 370 °C is produced, generating electricity with an efficiency of 37 % in a Rankine Cycle. The solar-electric peak efficiency is 22,4 %.

While SEGS I contains a thermal storage system to continue electricity generation about 2 hours after sunshine, SEGS II – IX are solar/fossil (also called: hybrid) plants. Short interruptions of thermal heat generation effected by clouds can be compensated by a fossil fuel fired burner. Note that the total yearly amount of fuel fired electricity generation is limited by law to 25 %. For more detailed information see [3,4].

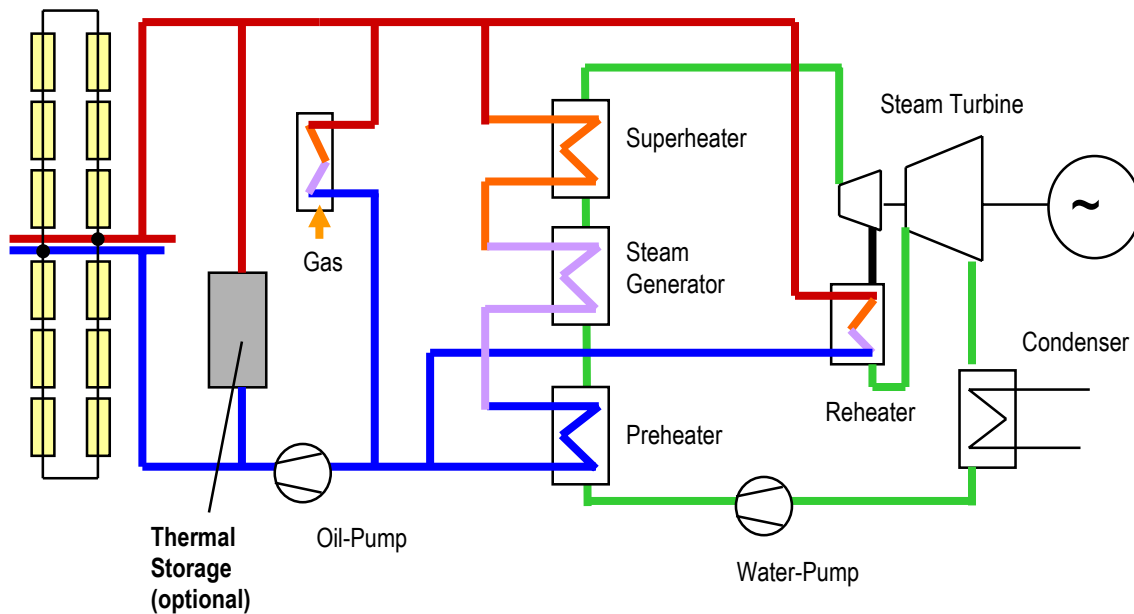

Figure 1: Principle Schema of a SEGS-Plant [4]

The Trough Collector

The trough collector represents the highest degree of concentration simplification. The curvature obeys only in a cross section to the ideal form and then extends linearly like a trough [2]. Following the sun by turning around its length-axis is sufficient to provide a line focus. A black absorber tube is located in this focus line, surrounded by a glass envelope. The space in between is evacuated to prevent heat losses by convection or conduction. A special optical selective coating permits to absorb 96 % of incoming short wave solar radiation, while the hot tube (up to 400 °C) emits only 7 % of the long wave radiation which a black body of the same temperature would emit. A heat transfer medium inside the absorber tube receives the heat and transports it to the heat exchanger, where it is fed to the power block.

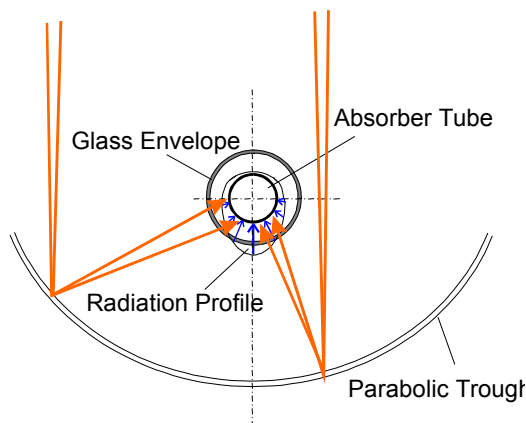

Figure 2: Principle scheme of a parabolic trough collector

Future Trough Concepts

A substantial break-through towards technical simplification and cost reduction can be expected from the Direct Solar Steam project (DISS), financed by the European Union [5,6]. Aim is to substitute the oil circuit, with the following advantages:

- only one heat transfer fluid circuit, no heat exchangers (reduces thermal losses and investment costs);
- no environmental impacts in the case of leakage (maintenance simplification);
- higher outlet temperatures of the solar field (no limitation by stability of the oil), leads to higher efficiency of the thermodynamic cycle;
- lower average field temperature, because more than two third of the collectors are used for water heating and evaporation at moderate temperatures, only a few collectors are used for superheating at higher temperatures.

The general problem of the DISS-concept is the question of controllability of the two-phase flow in horizontal tubes. Because of different heat transfer characteristics of the phases and inhomogeneous solar radiation profile, high temperature gradients on the circumference of the tube occur.

On the Plataforma Solar de Almería (PSA) one row with 550 m of modified LS-3 collectors was erected in 1999. Test operation started this year. Three concepts for direct steam generation will be tested (figure 3):

- Once Through Mode: the whole water amount fed to the inlet collector will be preheated, evaporated and superheated. This mode promises the highest cost reduction potential because of its simplicity, on the other hand it is the highest challenge with respect to stability and controllability of the process.
- Injection Mode: during the evaporation sector liquid water is injected to control the vapor phase by condensation. Additional tubes and valves as well as control units are necessary, related to higher investment costs.
- Recirculation Mode: water is preheated and partially evaporated in the first collectors, the two phases are then separated in an additional tank outside the collector. The vapor is fed back to the next collectors for superheating while the liquid phase is recirculated to the inlet. In this mode no stability or control problems are expected, but highest investment costs and additional pump losses minimize advantages compared with the two-circuit oil technology.

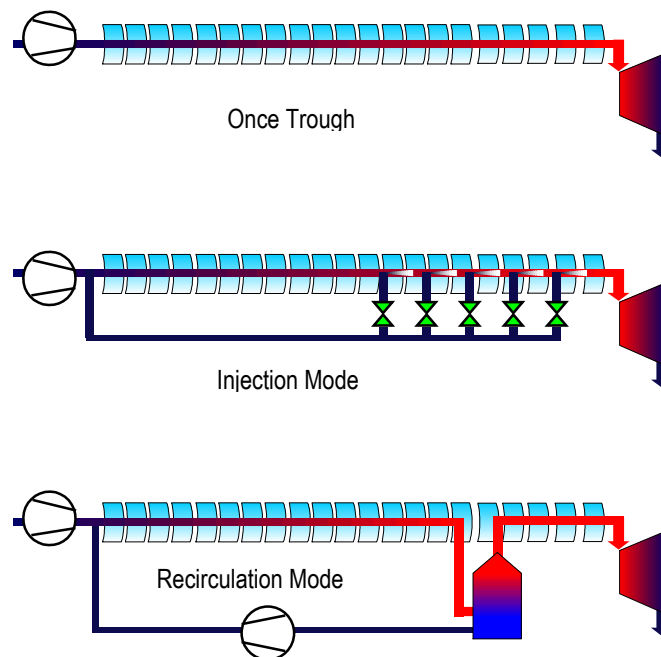

Figure 3: Different DiSS-concepts

2.3 Central Receiver System

The Central Receiver System – also called Tower System – mainly consists of a central tower with a receiver on the top and a mirror field surrounding the tower. Figure 4 shows the CESA1 test facility of the Spanish governmental “Centro de Investigaciones Energéticas, Medioambientales y Tecnológica” (CIEMAT) on the PSA in Southern Spain.

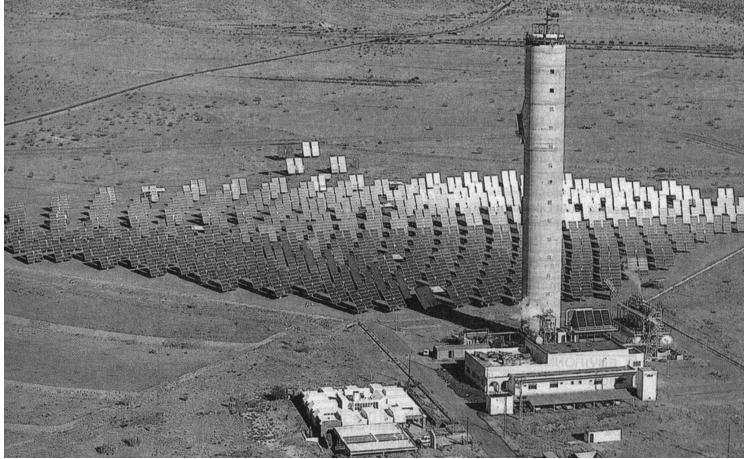

Figure 4: CESA1 test facility of CIEMAT on the Plataforma Solar de Almería

2.3.1 Heliostat-development

Each mirror – often called heliostat - has a two-axis drive mechanism and is individually controlled to reflect the direct sunlight to the receiver on the top of the tower. The mirrors are curved slightly, depending on the distance to the tower, to focus the sun.

Since the heliostat field is the largest single capital cost item of a CRS, a lot of R&D activities were done to decrease the costs. Figure 5 shows the development of recent years following two lines:

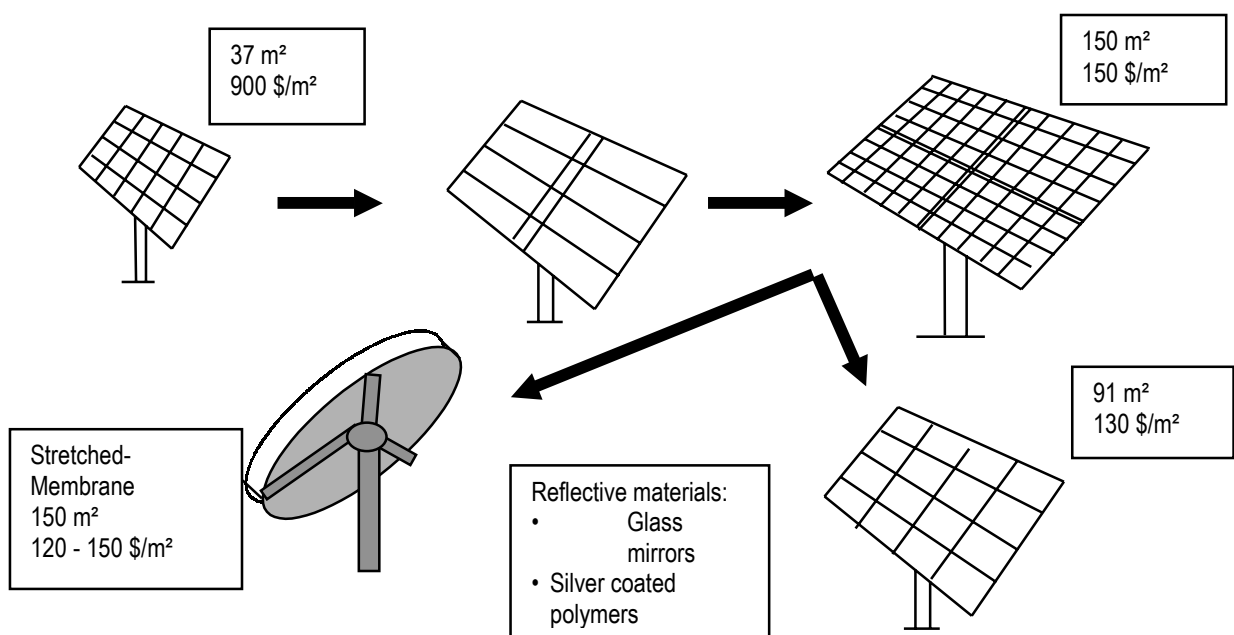

Figure 5: Heliostat development lines and specific prices [7,8]

In the first design back-silvered glass mirrors are fixed on a metal structure. The structure mainly consists of a half-timbering construction, fixed at a horizontal tube, the whole unit attached to a central pylon. The tube may rotate around the pylon axis and its own length axis. From the first prototype to now cost degradation was mainly effected by increasing the reflector area per unit.

The second design is the stretched-membrane concept: back-silvered thin glass mirrors or a reflective polymer film is attached to the front side of a thin metal membrane. The membrane forms a self-supporting low-weight structure in conjunction with the metal frame. A slight controlled vacuum between the membrane and the metal frame ensures exact focusing of the beam onto the receiver and allows easy defocusing by increase of pressure [2].

2.3.2 Different concepts and receiver designs

Up to now, the largest CRS plant - Solar One - operated from 1982 to 1988 in the Californian Mojave Desert near Barstow. A water/steam receiver system was used to generate an electrical output of 10 MW_e. The receiver consisted of vertical parallel tubes, arranged at the circumference of a cylinder. It was designed to generate superheated steam (100 bar, 515 °C). The receiver system was modified later to operate with molten salt as heat transfer fluid - Solar Two - providing better heat transfer and storage properties. A similar system was used before in the eighties at the “Thémis” experimental power plant (2.5 MW_e) in the French Pyrenees.

The first CRS-plant in Europe, a 500 kW_e plant with liquid sodium as heat transfer medium, started operation in 1981. The so called Small Solar Power System (SSPS-) plant was built on the PSA by the International Energy Agency (IEA). It demonstrated good operational characteristics and reliability, but some disadvantages regarding safety and maintenance. Because of a sodium fire in 1986, the plant was rebuilt, and the sodium components were removed. The plant is still used as test facility.

In Europe the utilization of air as heat transfer medium was favored since then. The main disadvantages of air, its low heat capacity and bad heat transfer characteristics, are compensated using a new receiver design: instead of a closed tube receiver a porous structure with large specific surface is used. In the PHOEBUS-program the structure consisted of wire mesh, ambient air sucked through this structure was heated up to 700 °C. This concept (figure 6) was tested on the CESA-1 test facility, a 1 MW_e experimental power plant built by CIEMAT on the PSA beside the SSPS-field. A 10 MW_e power tower (PS10) is currently under construction near Sevilla, Spain, with support from the European Union.

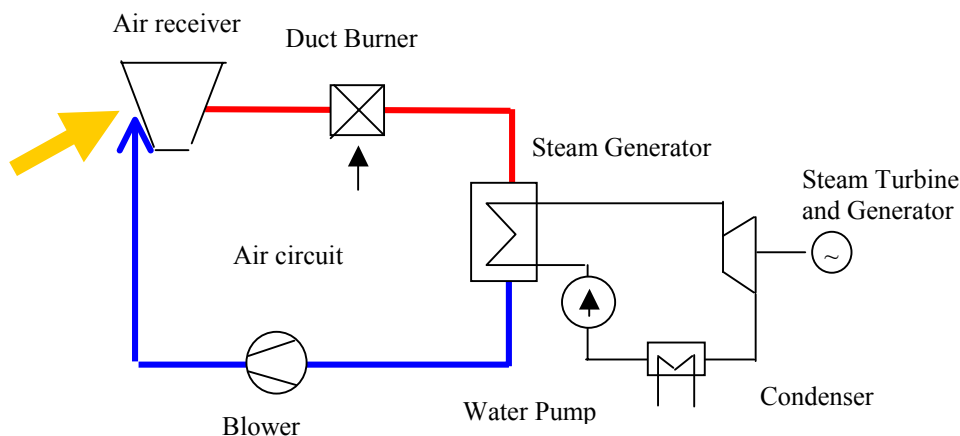

Figure 6: PHOEBUS Concept

Different efforts are currently made to reduce the receiver size by using porous ceramic materials instead of the wire mesh, which can start much higher solar concentration. This enables higher steam temperatures and results into higher thermal-electric efficiency of the power cycle.

The above mentioned concepts feed the solar energy to a Rankine Cycle, using a steam turbine to drive the electrical generator. The thermal-electrical efficiency is technically limited to 45 %.

A modern Combined Cycle Plant generates electricity with overall efficiencies up to 60 % in two steps: a gas turbine, fired with compressed gas and air, drives a first generator, secondly the hot exhaust gases from the gas turbine are used to produce steam, generating electricity by a water/steam cycle. Idea of the REFOS-concept [9] is to provide solar preheated compressed air, fed to the combustion chamber to burn the gas. Thus the solar energy is converted more efficiently into electricity.

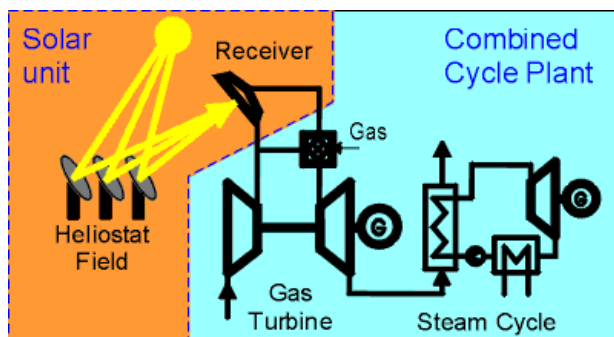

Figure 7: REFOS: Cycle-Scheme [9]

In principle a receiver similar to the above mentioned wire mesh air receiver was used. The front side is closed by a quartz glass window. First tests were done, using the CESA-1 system. An air outlet temperature of 800 °C at a pressure of 15 bar was realized.

Future developments using ceramic absorber structures may rise the air outlet temperature up to 1200 °C. Then fossil co-firing would become redundant.

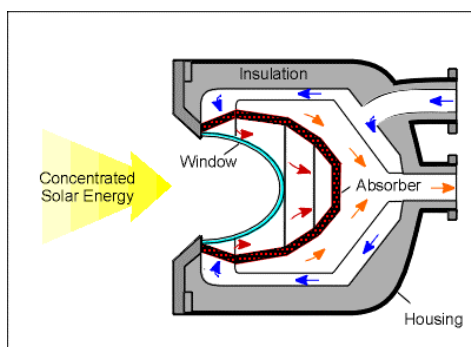

Figure 8: The REFOS-Receiver [9]

2.4 Dish/Stirling Technology

Dish collector systems are the technology of choice for distributed electricity generation, i.e. remote power, off-grid power, village power supply. A parabolic reflector in the shape of a dish is used to focus the sun's rays onto a receiver, i.e. a Stirling engine, mounted above the dish at its focal point. Dishes achieve the highest performance of all concentrator types in

terms of annual system efficiency and peak solar concentration because they track the sun in two axes, keeping their aperture perpendicular to the sun at all times [2]. A peak efficiency of more than 30 % can be achieved.

Figure 9 shows three Dish/Stirling Systems tested on the PSA with an electrical power of 9 kW (SOLO V-160) each. The concentrator was developed by Schlaich, Bergemann and Partner, applying the stretched membrane technique similar to the heliostat construction described in chapter 2.3.1



Figure 9: Dish/Stirling System (Schlaich, Bergemann and Partners, engine from SOLO) tested at the PSA

2.5 Cost comparison

For the DCS and CRS levelized electricity costs (LEC) have been estimated and – in the case of the Californian SEGS-plants – verified. Cost degradation during recent years for the different systems and prognosticated costs of future projects are shown in Figure 10.

For large applications (> 100 MW) the power tower has the greatest cost reduction potential. Prognosticated LEC for a 200 MW salt tower, which could be realized in 2010, are 0.06 Euro/kWh, what is in the same order of today's wind power electricity costs.

Parabolic trough technology with direct steam generation will achieve same costs, also at a less favorable location (2400 kWh/m²a in North Africa compared with 2700 kWh/m²a in California).

As mentioned above parabolic dishes using a Stirling engine have the mid-term potential to cover the small decentralized power demands. In [2] the LEC for a 1 MWe dish/stirling system is mentioned to be 0.5 Euro/kWh.

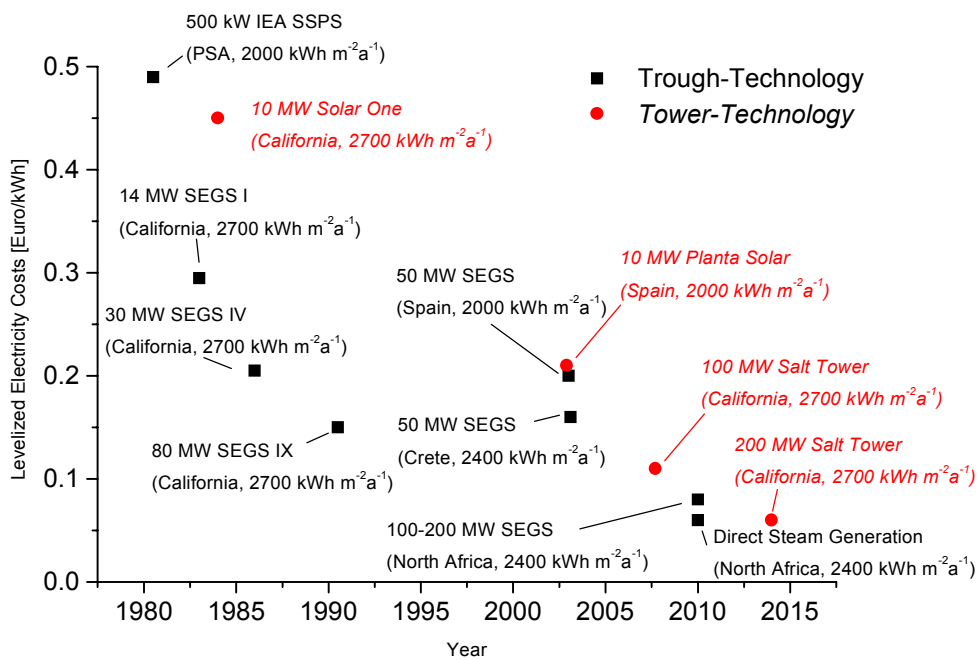

Figure 10: Levelized Electricity Costs (Euro/kWh_e) development for trough and tower power plants [2,6]

To resume and to give an outlook, test facilities and commercial solar thermal power plants currently in operation as well as plants planned in the near future are shown on the world map in Figure 11.

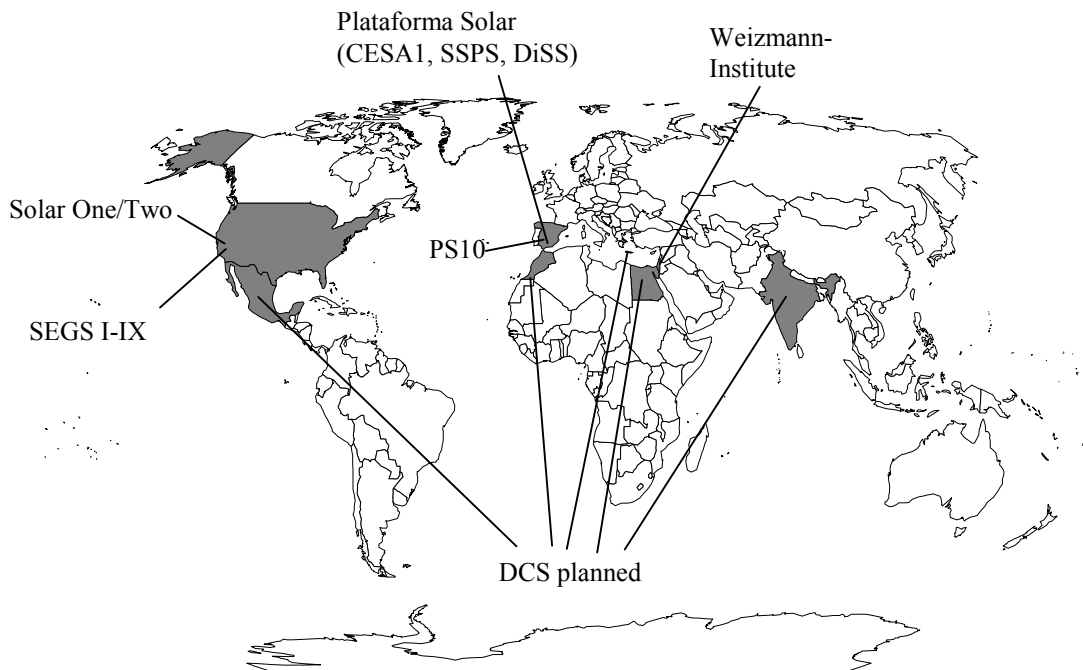

Figure 11: World map with solar thermal test facilities and commercial plants in operation

In Morocco, Egypt, India and Mexico integrated combined cycle power plants of approximately 150 MW_e are planned as solar fossil plants using parabolic trough fields with an equivalent capacity of 30 – 50 MW_e. They are financed by the world bank with 50 Million US\$ each. On the Greek island Crete the European Union supports a 50 MW_e trough system [10]. Near Sevilla in Southern Spain a first 10 MW_e solar tower will be erected in the next two years, also supported by the European Union (PS10).

3 Process Heat

Parallel to the development of collectors for the solar thermal electricity generation in the 80's, several producers developed parabolic trough collectors for process heat generation [2]. E.g. in Aguas, Portugal, a 1280 m² field of MAN-collectors supplied heat to a dairy at a temperature of 280°C. The largest system was erected in Chandler, Arizona, USA with 5620 m² aperture area consisting of collectors from the company SKI delivering heat at 260°C. After this active period only the company Industrial Solar Technology (IST), Golden, Colorado, kept on selling their collector system.

In the last years several companies started selling parabolic trough collectors for the temperature range between 50°C – 300°C, all of them with one-axis tracking. One recent installation (1998/99, 1584 m²) is located in Phoenix, USA with parabolic troughs from IST. Another project under construction is a process steam plant in Cairo, Egypt, also using IST-collectors.

For testing purposes and for demonstration of the parabolic trough technology a collector field from IST consisting of twelve modules with 168 m² aperture area has been installed at DLR in Cologne (Figure 12) with financial support from the „Arbeitsgemeinschaft Solar“ of the federal state Northrhine-Westfalia. The size of the field allows for realistic efficiency measurements, which include e.g. soiling of the collector surface and blocking and shading of structural elements. Inlet temperatures between 20°C and 200°C and mass flows up to 10 m³/h are delivered by a balance of plant, using pressurized water as heat transfer medium. The receiver is not evacuated and contains an absorber tube with black nickel selective coating. A polymeric reflective film glued to an aluminum sheet concentrates the radiation.



Figure 12: IST-Trough collector at DLR, Cologne

Performance data of the collector as the efficiency for temperatures up to 200°C and the Incident Angle Modifier were measured [11]. These data were used for calculations (in TRNSYS) of the annually accumulated energy, which can be expected under various climates.

For the simulations a steady mean transfer fluid temperature was assumed. Effects from soiling and shading of the collector rows onto each other are included, field piping losses are neglected. Simulations for a central European climate (Test Reference Year Würzburg, Germany) resulted in an energy yield of more than 400 kWh/m² per year in the low temperature range.

Improvements of the optical performance recently discussed [12], would lead to a better incident angle modifier and a higher optical efficiency (Improved Trough). Results of equal simulations with a flat plate collector and a vacuum tube collector with CPC (no shading or soiling assumed) permit a comparison of the trough collector's yield [13]. The annual energy yield is presented in figure 13 as a function of the fluid temperature in the range of 50 to 200°C.

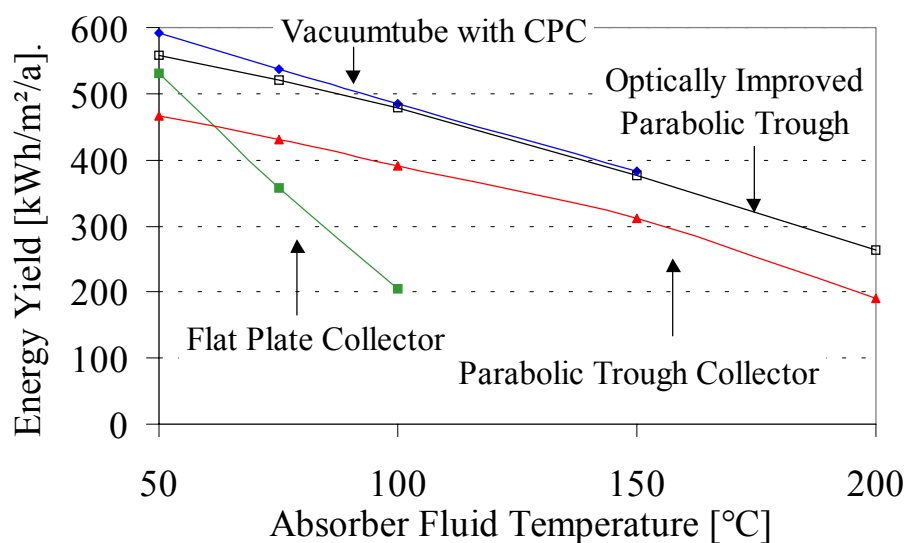

Figure 13: Simulated annual energy yield with different collector systems in a central European climate

The trough collector is relatively insensitive to rises in the absorber fluid temperature. This is the consequence of its small receiver surface area, which leads to low heat losses. The trough's high energy yield results also from its tracking system: the trough already catches the sun in the morning until the late evening. At temperatures above 65°C the parabolic trough collector therefore yields more energy than a flat plate collector. The highest yield up to 150°C can be achieved with a vacuum tube with CPC because it has low thermal losses and uses the global radiation.

Finally decisive are the costs per kilowatt-hour for solar heat. Included in the costs are the investment and installation costs of the collector field and the operation and maintenance costs (Table 1). Because thermal losses increase with collector temperature, the heat price strongly depends on the mean fluid temperature (Figure 14).

Table 1: Costs of collector systems assumed for a solar field of 1000m² aperture area

	Investment Costs €/m ²	O&M /a €/m ²	Annual Costs* €/m ²
Parabolic Trough Collector	250	5	30
Flat Plate Collector	250	2.5	28
Vacuum tube with CPC	500	2.5	54

*Annuity + O&M/a (Life Time 15 years, Interest Rate 6 %)

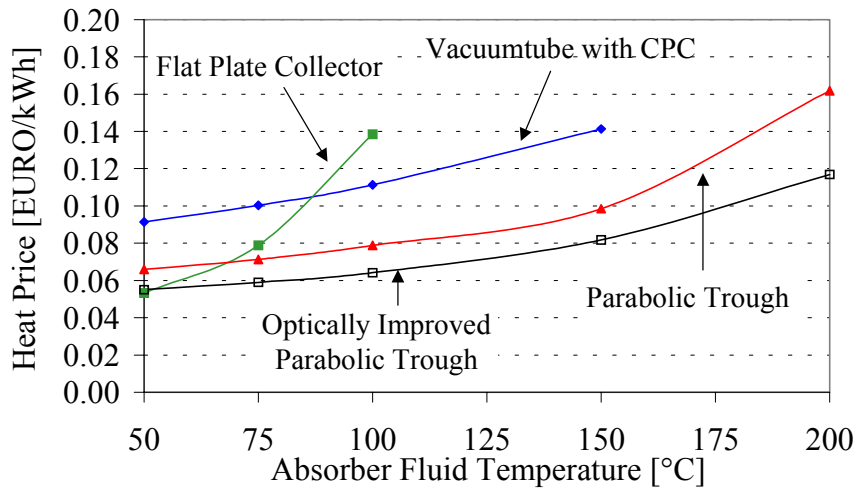

Figure 14: Heat Prices for different collector systems as a function of the fluid temperature

In the temperature range up to 150°C, heat costs of less than 0.1 Euro can be achieved. The supply of a great heat consumption around 100°C can now also be achieved at nearly the same costs as at low temperatures.

4 Summary and Conclusion

In this paper the technology for solar thermal electricity and process heat generation was presented. Both, distributed collector (trough) systems and central receiver (tower) systems, have the potential to reach economic competitiveness with other renewables like today's very popular wind power. Levelized electricity costs of 0.14 Euro/kWh_e are realized, costs of less than 0.1 Euro/kWh_e in the solar belt may be reached after some second generation improvements. The high-voltage DC power transfer enables efficient power transport over some thousands of kilometers, e. g. from North Africa to Central Europe. Plant sizes are in the order of magnitude of some 10 MW_e to 200 MW_e. For distributed electricity generation in the order of some 10 kW_e, the dish/stirling system was presented.

Concerning process heat generation the great performance of parabolic trough collectors was pointed out. For temperature levels over 75 °C and heat demands of some 100 kW, trough systems show the lowest heat prices even in a central European climate. Nevertheless, experiences with such systems are low and have to be increased before market penetration occurs.

5 Literature

1. M. A. Geyer, Thermal Storage for Solar Power Plants, in: Solar Power Plants, C.-J. Winter, R. L. Sizmann, L.-L. Vant-Hull (Eds.), Springer-Verlag Berlin (1991), S. 199-214
2. W. Meinecke, M. Bohn, Solar Energy Concentrating Systems, M. Becker, B. Gupta (Eds.), C. F. Müller Verlag, Heidelberg (1995)
3. M. Mohr, P. Svoboda, H. Unger, Praxis solarthermischer Kraftwerke, Springer-Verlag Berlin Heidelberg 1999
4. M. Geyer, A. Holländer, R. Aringhoff, P. Nava, Hälfte des weltweit produzierten Solarstroms, in: Sonnenenergie (1998), Nr. 3, S. 33-37

5. K. Hennecke, E. Zarza, Direct solar steam generation in parabolic troughs (DISS). Update on project status and future planning (1999) J. Phys. IV France 9
6. DISS-phase I PROJECT: Final Project Report, 1999, CIEMAT (ed.), Madrid, ISBN 84-7834-358-x
7. Sandia National Laboratories, Albuquerque, USA
8. IEA-SolarPACES Technical Report No. III – 1/00, Task III: Solar Technology and Applications, June 2000
9. R. Buck, E. Lüpfert, F. Téllez, Receiver for Solar-Hybrid Gas Turbine and CC Systems (REFOS), Proc. 10th Int. Symp. on Solar Thermal 2000, 8 – 10 March 2000, Sydney, Australia
10. R. Aringhoff, THESEUS auf Kreta, in: Sonnenenergie (1998), Nr. 3, S. 41-40
11. D. Krüger, A. Heller, K. Hennecke, K. Duer (2000), Parabolic Trough Collectors for District Heating Systems at High Latitudes? - A Case Study, in: Eurosun 2000, ISES-Europe Congress, Copenhagen Elvang A.-E., Iversen S. (ed.)
12. K.-J. Riffelmann, Th. Fend, R. Pitz-Paal, (2000), Parabolic Trough Collector Efficiency Improvement Activities, in: 10th Int. Symp. - Solar PACES - Solar Thermal Concentrating Technologies, Sydney, Australia April 2000, Kreetz, H., Lovegrove, K., Meike, W. (ed.), pp. 121 – 129
13. D. Krüger, K. Hennecke, J. Richartz, P. Mumm (2000), Untersuchung von Leistungsmöglichkeiten eines Leichtbauparabolrinnenkollektors im mitteleuropäischen Klima, in: 12. Int. Sonnenforum 2000, Freiburg, Deutsche Gesellschaft für Sonnenenergie (Hrsg.), in Druck